



CHANTLAND

M H S

Since
1943

Material Handling Solutions

BAG KICKER

4217 BELT CONVEYOR

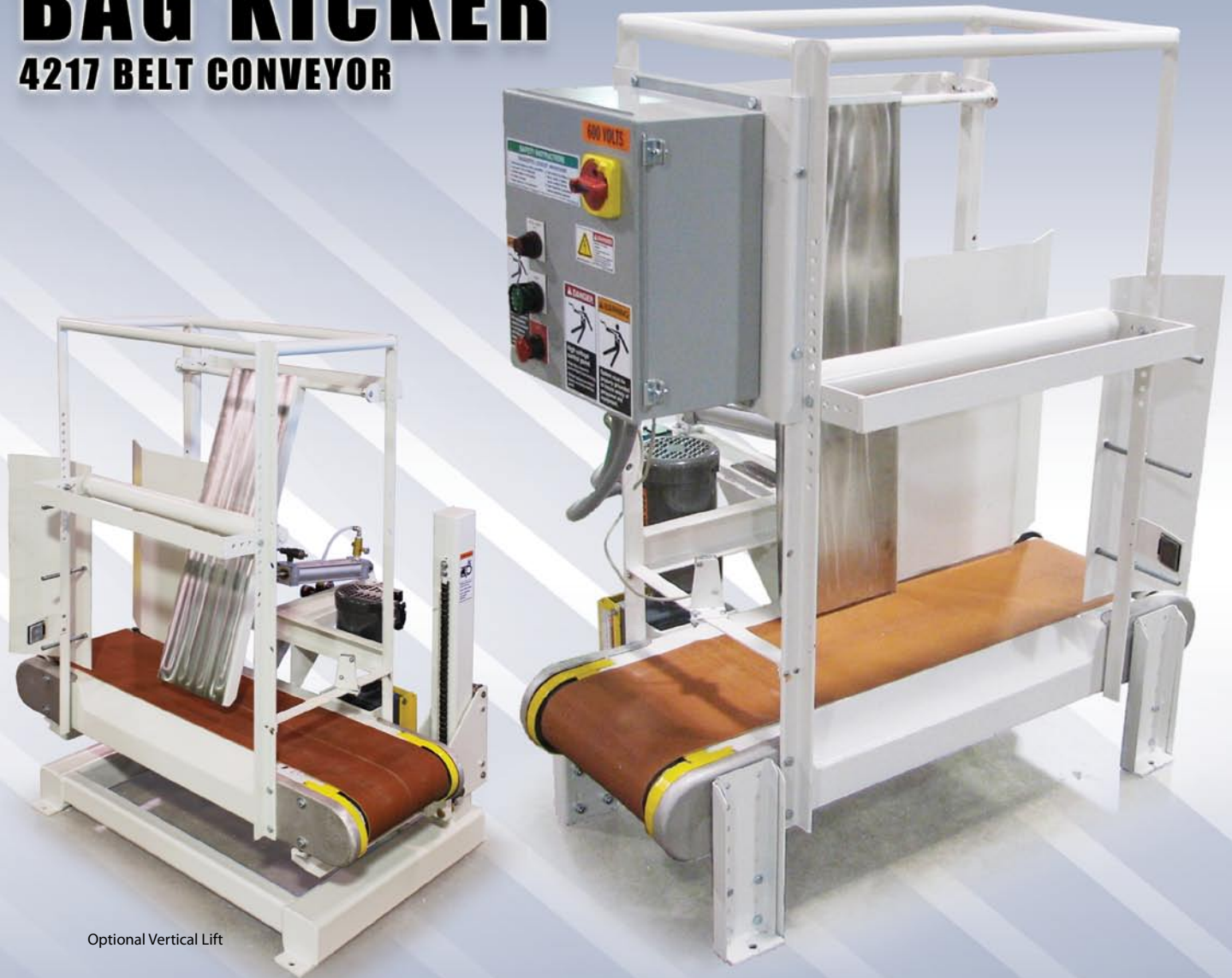

Optional Vertical Lift



Specialized conveyor design automatically transfers filled bags from an upright position to a horizontal bottom first position at a right angle to the filling and closing line.

SOLUTIONS

WWW.CHANTLAND.COM

BAG FILLERS ♦ CONVEYERS ♦ PALLETIZERS ♦ SYSTEMS



BAG KICKER

MODEL 4217

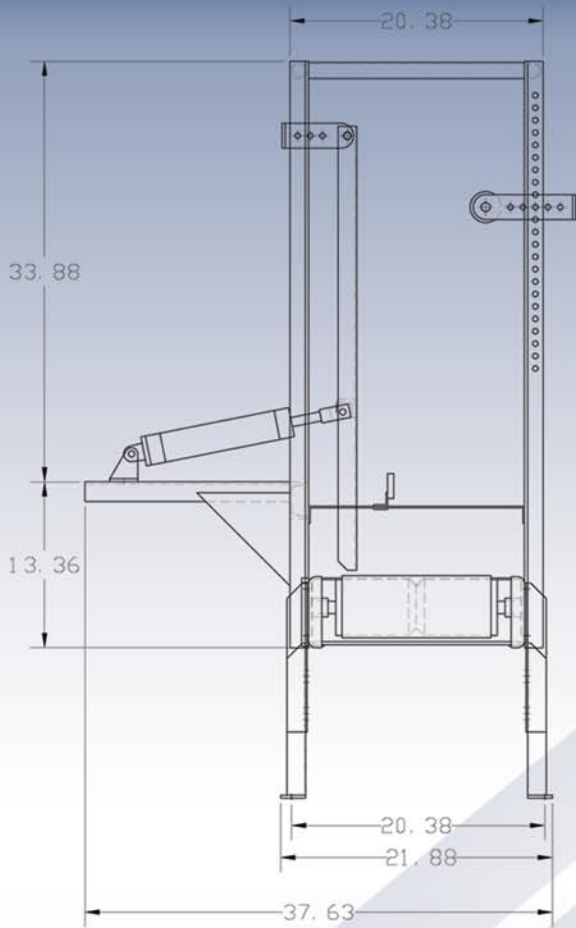

NOTE: Right Hand Kicker Shown
Left Hand Kicker Opposite

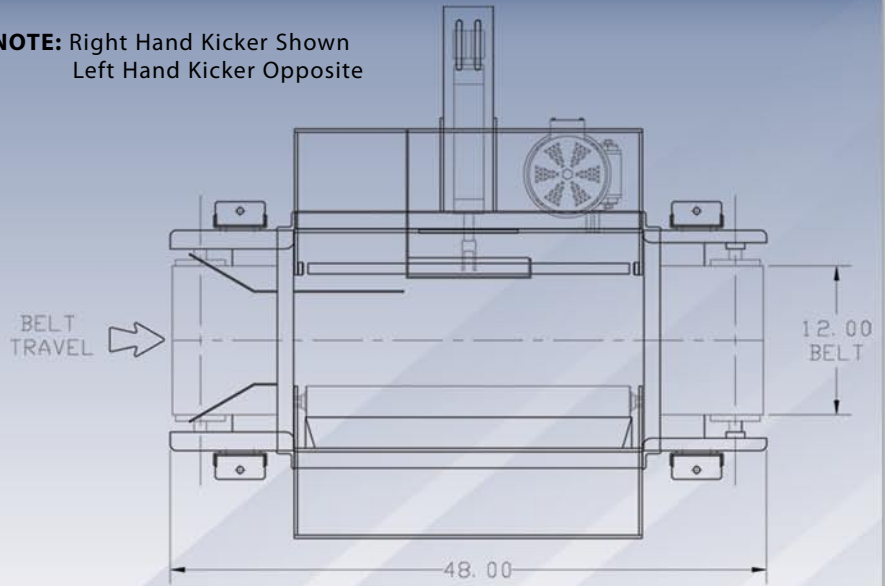

DESIGN FEATURES:

- ◆ Fully adjustable to accommodate different bag sizes.
- ◆ Stainless steel kick plate, slip top belt and integral frame slide for smooth transition from upright position.
- ◆ V-guide molded to underside of belt for positive belt tracking.
- ◆ Lagged drive pulley for maximum belt traction.
- ◆ Supports adjustable for 12"-20" top of belt height.
- ◆ NEMA 12 electrical controls: 230/460 V., 60 Hz., 3 Ph.
- ◆ Pneumatic controls: 3 CFM per cycle @ 80 PSI.
- ◆ Heavy formed mild steel conveyor frame.
- ◆ Industrial enamel finish.

AVAILABLE FEATURES:

- ◆ Manual or electric vertical lift assembly.
- ◆ Variable speed controls.
- ◆ Wash down, corrosive and explosion proof electrical packages.
- ◆ Stainless steel construction.
- ◆ Special finish coatings.

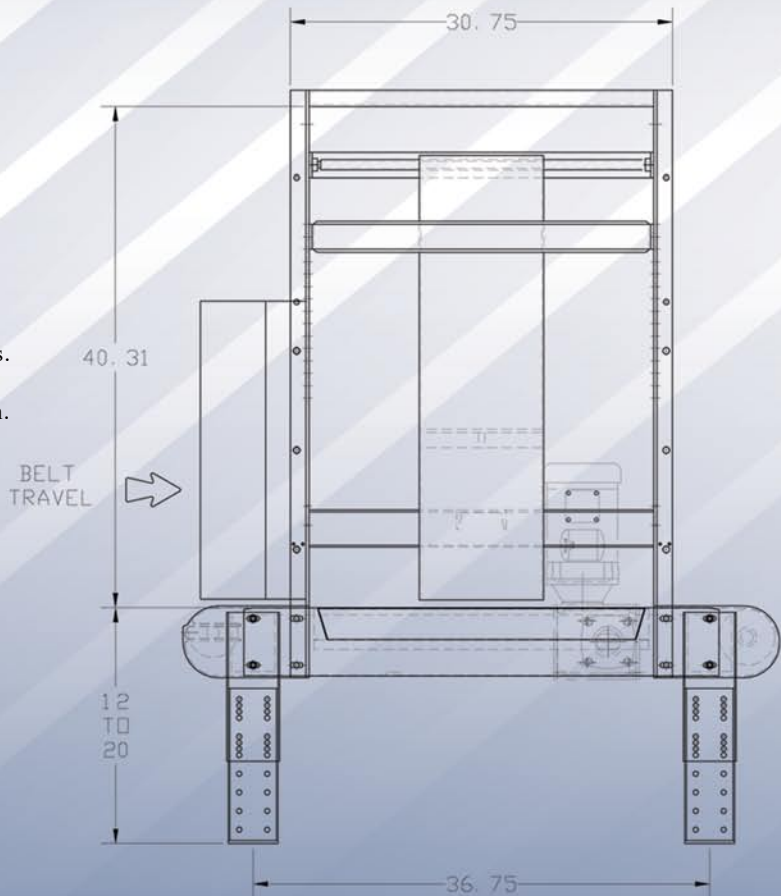

Shipping Weight: Approximately 670 lbs.

BAG FILLERS

CONVEYORS

PALLETIZERS

SYSTEMS

PO Box 279, Humboldt, Iowa, U.S.A. 50548 / Ph. 515.332.4045 Fax 515.332.1502

www.chantland.com