



CHANTLAND

M H S

Material Handling Solutions

Since
1943

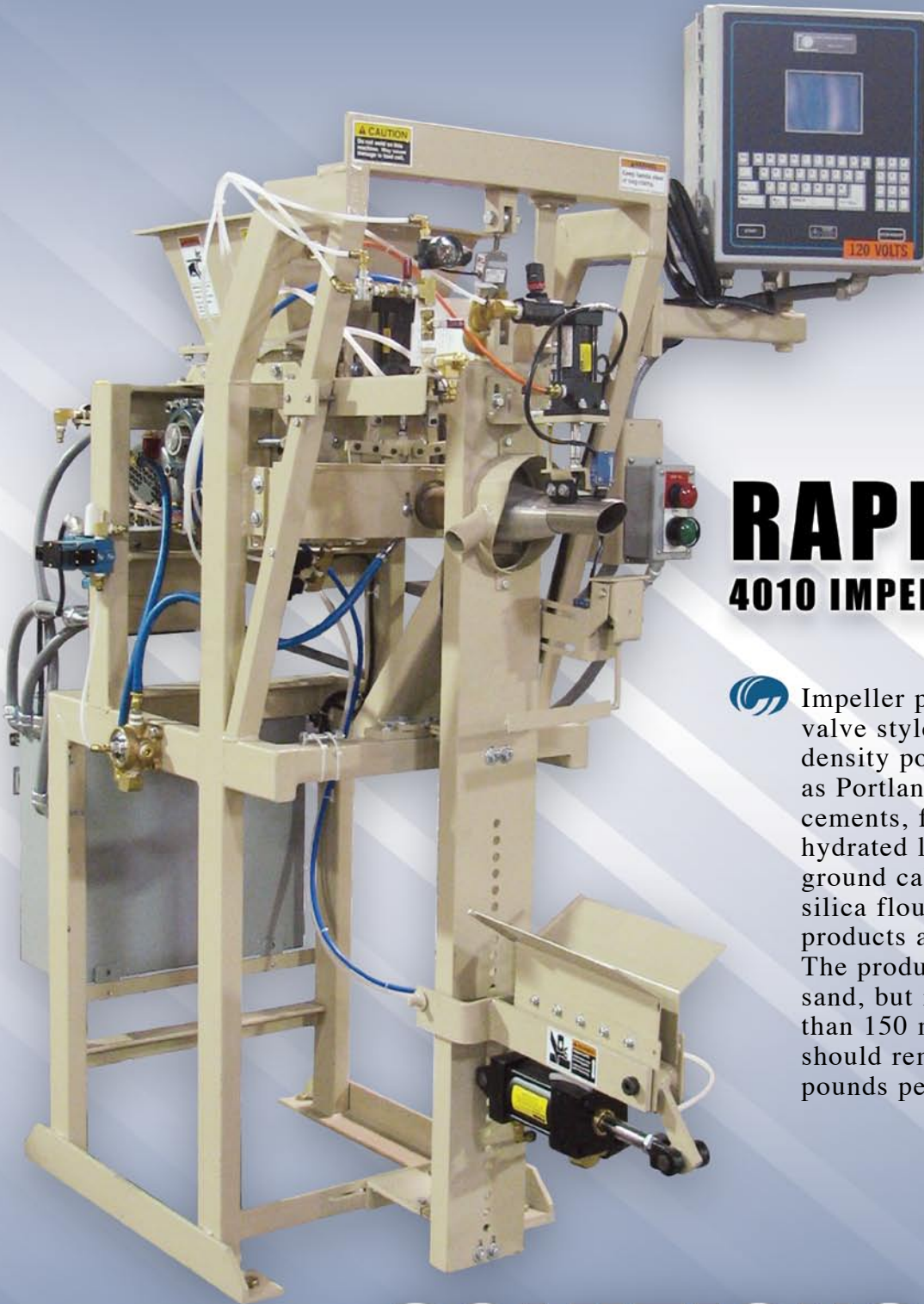

RAPID FLOW 4010 IMPELLER PACKER



Impeller packers are used to fill valve style bags with high bulk density powder products such as Portland and masonry (plastic) cements, fine ground gypsum, hydrated lime, fly ash, fine ground calcium carbonate, talc, silica flours, insecticides, clay products and similar products. The products can contain some sand, but it must not be greater than 150 mesh. Bulk densities should remain greater than 50 pounds per cubic foot.

SOLUTIONS

WWW.CHANTLAND.COM

BAG FILLERS ♦ CONVEYERS ♦ PALLETIZERS ♦ SYSTEMS



RAPID FLOW

4010 IMPELLER PACKER

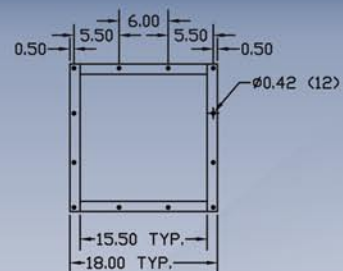
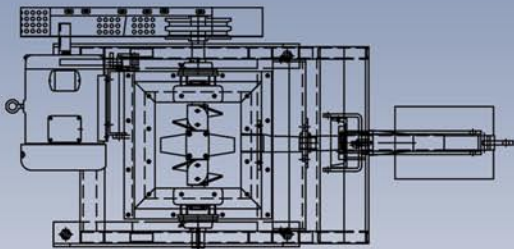

TOP HOPPER FLANGE DETAIL
NOTE: DIMENSIONS SHOWN TYP. ON ALL SIDES OF FLANGE.

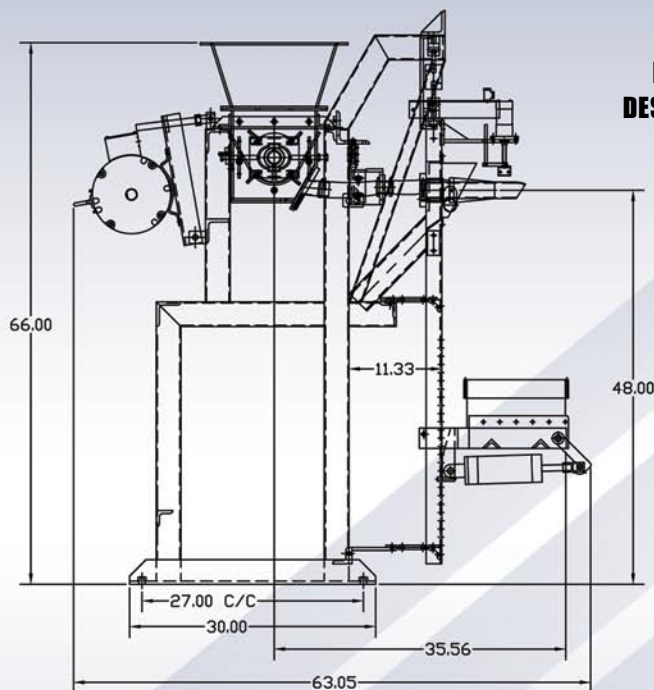

**OPTIONAL
LOAD CELL
DESIGN SHOWN**

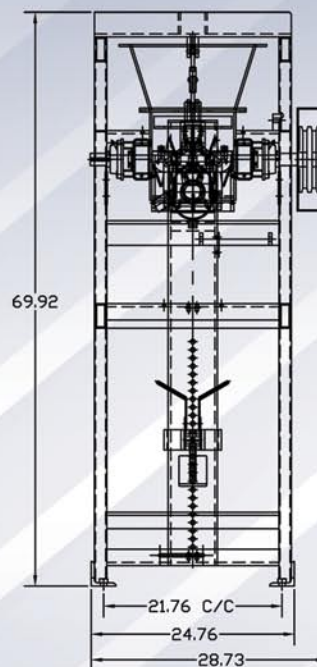

DESIGN FEATURES:

- ◆ Low overall height allows for ease of application and service.
- ◆ Mechanical scale beam with 3:1 ratio and inverted hardened points ensure accurate fill weights.
- ◆ Integral dust collection hood and manifold to maintain clean work atmosphere.
- ◆ Dual wing augers deliver constant product flow to the impeller.
- ◆ Pneumatic bag clamp.
- ◆ Stationary bag chair.
- ◆ 7.1/2 HP TEFC drive.
- ◆ NEMA 12 electrical controls.

AVAILABLE FEATURES:

- ◆ Automatic fill start with bag-in-place switch increases production rates and prevents accidental spills.
- ◆ Load cell weighing.
- ◆ Abrasion resistant wing augers, impeller and wear points.
- ◆ Air operated bag discharge chair.
- ◆ Heavy duty outrigger casters with locks.
- ◆ Special finishes.
- ◆ Special electrical packages such as NEMA 4 washdown.

STANDARD SPECIFICATIONS:

- ◆ Utility Requirements: **Electrical:** 230/460 V., 60 Hz., 3 Ph.;
- ◆ **Air:** 1.1/2 CFM @ 80 PSI per cycle
- ◆ Fill Weights: 20 to 110 lbs.
- ◆ Fill Rates: 4 to 12 bags per minute depending upon product characteristics.
- ◆ Weight Accuracy: 6 to 8 oz. depending upon product characteristics.
- ◆ Shipping Weight: Approximately 1,300 lbs.

BAG FILLERS

CONVEYORS

PALLETIZERS

SYSTEMS

Hwy. 3 East, PO Box 279, Humboldt, Iowa, U.S.A. 50548 / Ph. 515.332.4045 Fax 515.332.1502

www.chantland.com